

- NOTES:**
1. VALVE HOUSINGS ARE CAST OF IRON OR ALUMINUM; FABRICATED OF STEEL OR STAINLESS STEEL. ALL ROTORS ARE FABRICATED OF STEEL OR STAINLESS STEEL.
 2. VALVE HOUSINGS ARE AVAILABLE WITH ANY COMBINATION OF SQUARE OR ROUND INLET AND OUTLET. ROUND FLANGES MATCH 150# ANSI DRILLING.
 3. STANDARD HOUSINGS ARE DESIGNED FOR 15 PSI (MAX) INTERNAL & DIFFERENTIAL @ 250 DEGREES F.
 4. END PLATE O-RINGS ARE OPTIONAL AND WILL BE FURNISHED ONLY WHEN SPECIFIED.
 5. AIR PURGE CONNECTIONS 1/8" NPT WITH BRASS LANTERN RINGS ARE OPTIONAL AND WILL BE FURNISHED ONLY WHEN SPECIFIED.
 6. VENT WITH SCH 10 PIPE IS OPTIONAL AND WILL BE FURNISHED ONLY WHEN SPECIFIED. VENT CONNECTION WILL CHANGE ROTOR ROTATION TO COUNTER-CLOCKWISE.

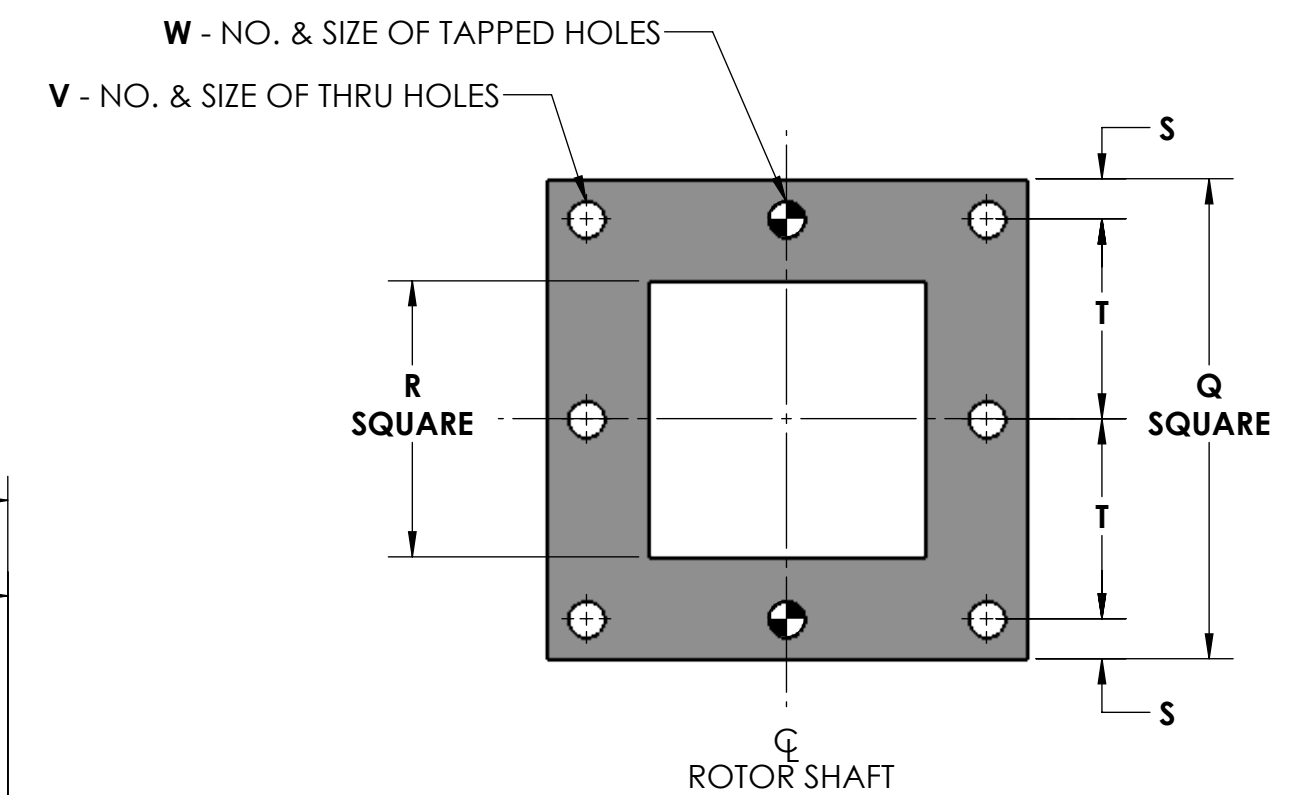
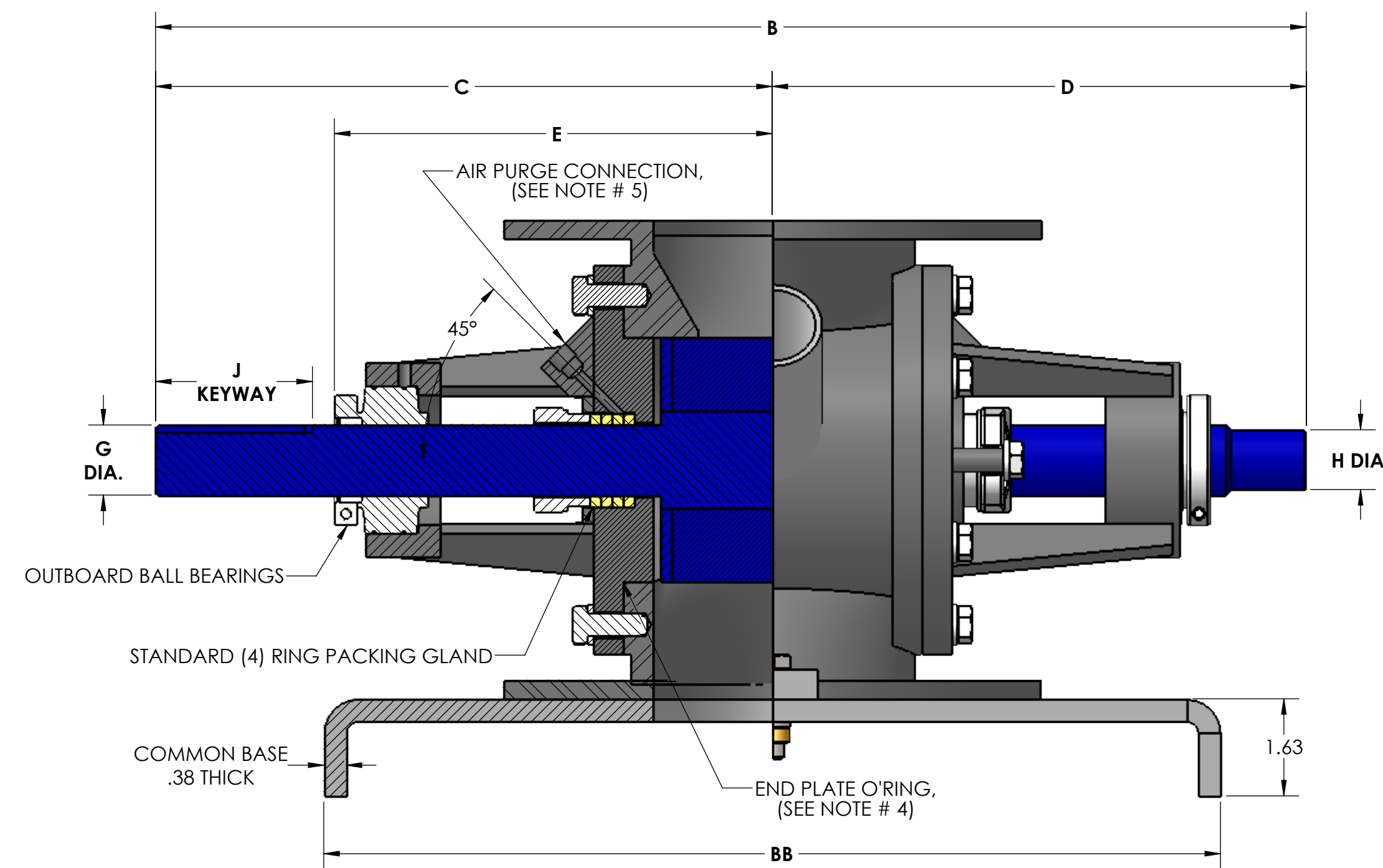
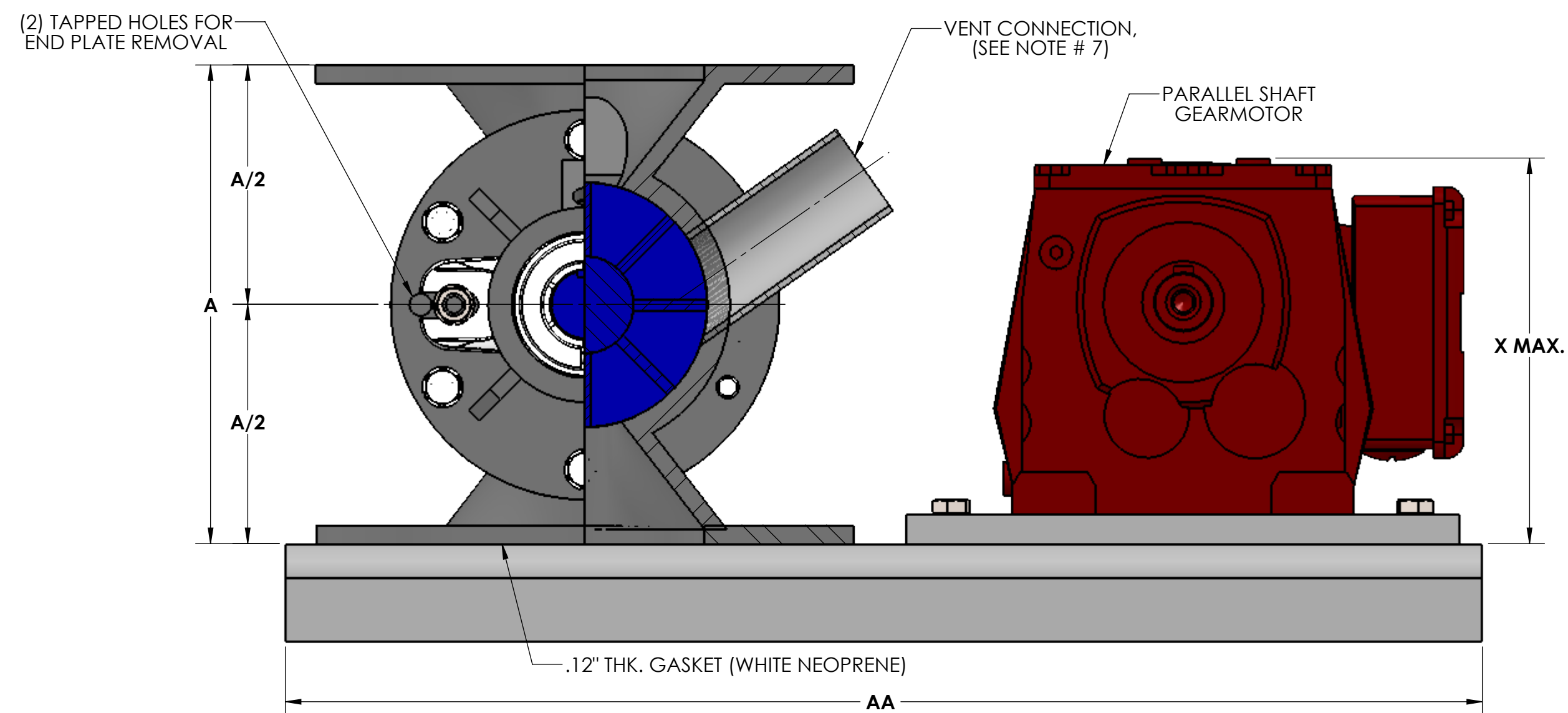

SQUARE FLANGE DETAIL
(SEE NOTE # 2)

ROTOR DIA x LG.	AS	BS	CS	STD RPM	VENT SIZE	STD HP	A	B	C	D	E	F	G	H	J	K	L	M	N	P	Q	R	S	T	U	V	W	X	Y	AA	BB	WEIGHT C/S
4 x 4	.0169	.011	.00741	38	1.25	.50	8.00	19.25	10.31	7.69	7.31	.31	1.19	1.00	.25 x .12 x 2.62	9.00	7.50	4.00	(4) .75	(4) .62-11UNC-2B	7.50	4.00	.62	3.12	N/A	(6) .56	(2) .50-13UNC-2B	7.88	20.38	20.00	15.00	205
5 x 5	.0362	.0235	.0117	38	1.50	.50	9.00	20.25	10.81	8.19	7.81	.44	1.19	1.00	.25 x .12 x 2.62	10.00	8.50	5.00	(4) .88	(4) .75-10UNC-2B	8.50	5.00	.62	3.62	N/A	(6) .56	(2) .50-13UNC-2B	7.88	20.38	20.50	15.50	220

GENERAL TOLERANCES
UNLESS OTHERWISE SPECIFIED THE FOLLOWING SHALL APPLY

MACHINING - .XX= .02 .XXX= .005 ANGLE= .50°
SURFACE ROUGHNESS HEIGHT 63 MICRONS OR LESS
FABRICATION - UNDER 6 6 TO 24 24 TO 60 OVER 60
± .06 ± .12 ± .19 ± .25

UNLESS OTHERWISE SPECIFIED DIMENSIONS ARE IN INCHES

REV. NO.	DESCRIPTION	DATE	BY
REVISIONS			
CUSTOMER			
CUST. NO.			
YOUNG ORDER NO.			
TITLE			
YOUNG INDUSTRIES MODEL 'LH' ROTARY VALVE, SIZE 4" - 5", CLASS 15 WITH PARALLEL SHAFT DRIVE, SHROUDED ROTOR STANDARD DIMENSION SHEET			
YOUNG INDUSTRIES, INC. MUNCY, PENNSYLVANIA 17756 TELEPHONE: 570-546-3165			
DRAWN BY: BMF		DATE DRAWN: 3/21/16	
CHECKED BY:		SCALE: 1:2	
DRAWING NUMBER		REV:	
		S-4-6396	