

NOTE: RIGHT HAND DISCHARGE W/ TOP DRIVE SHOWN
LEFT HAND DISCHARGE OPPOSITE

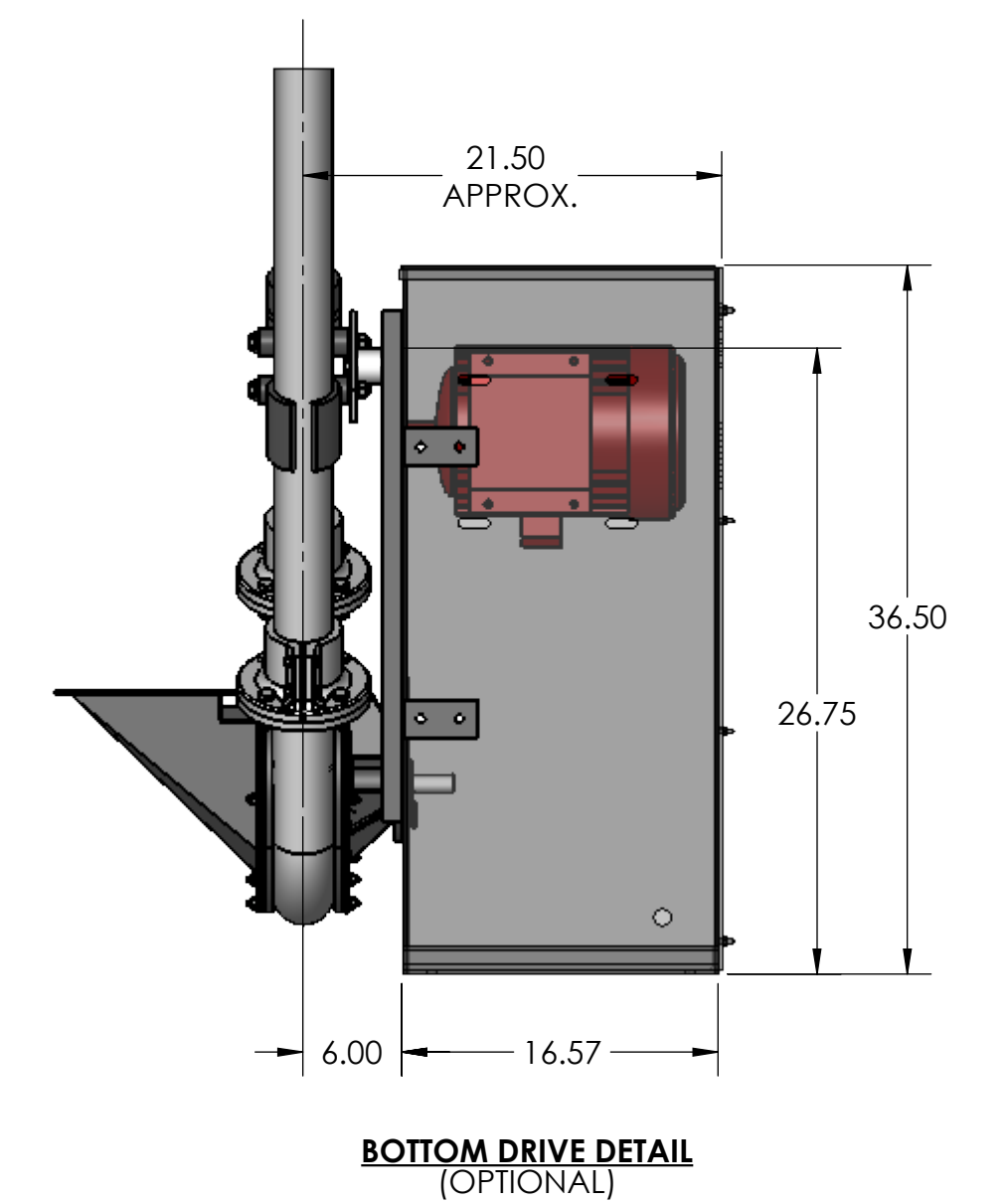
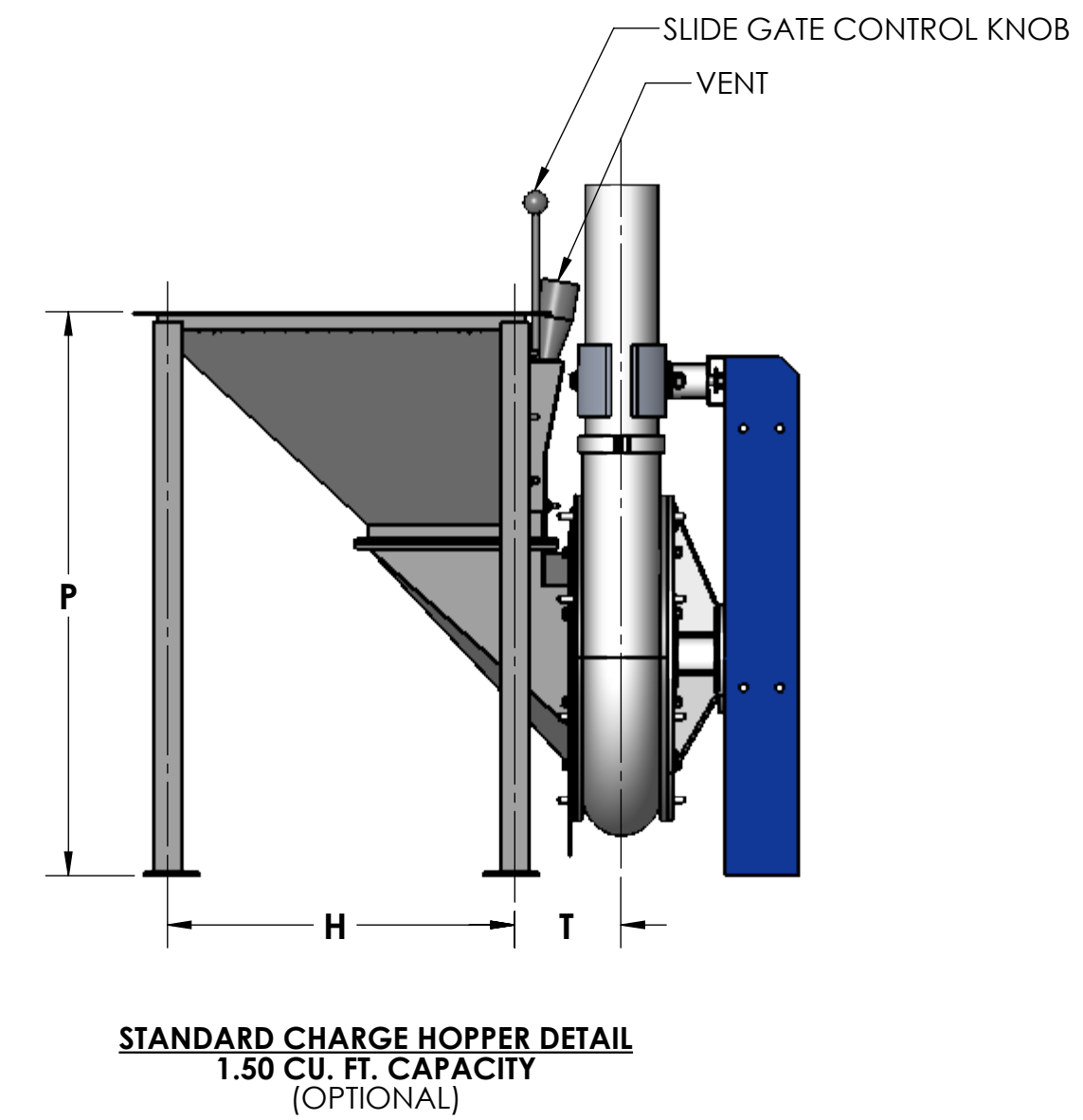
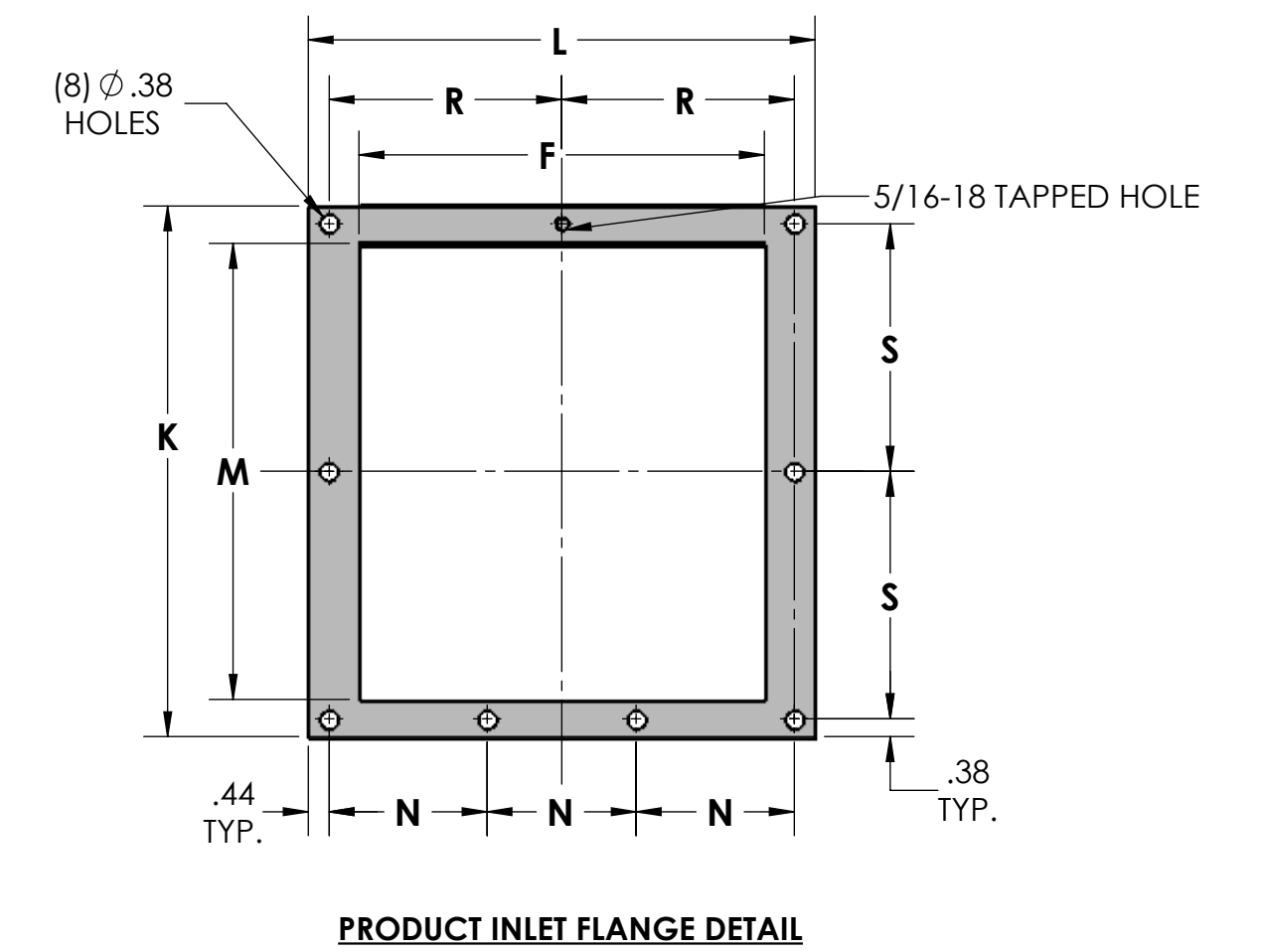
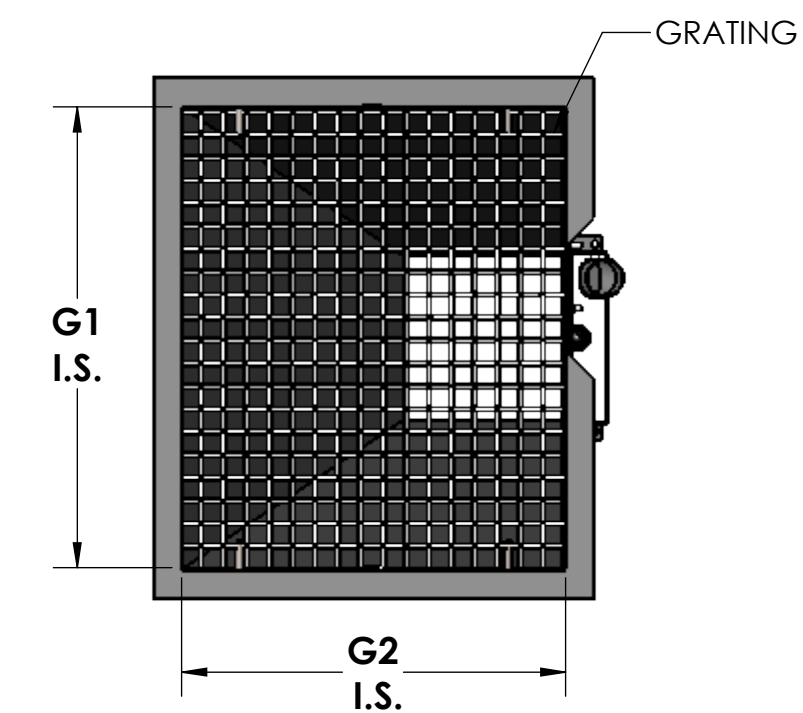
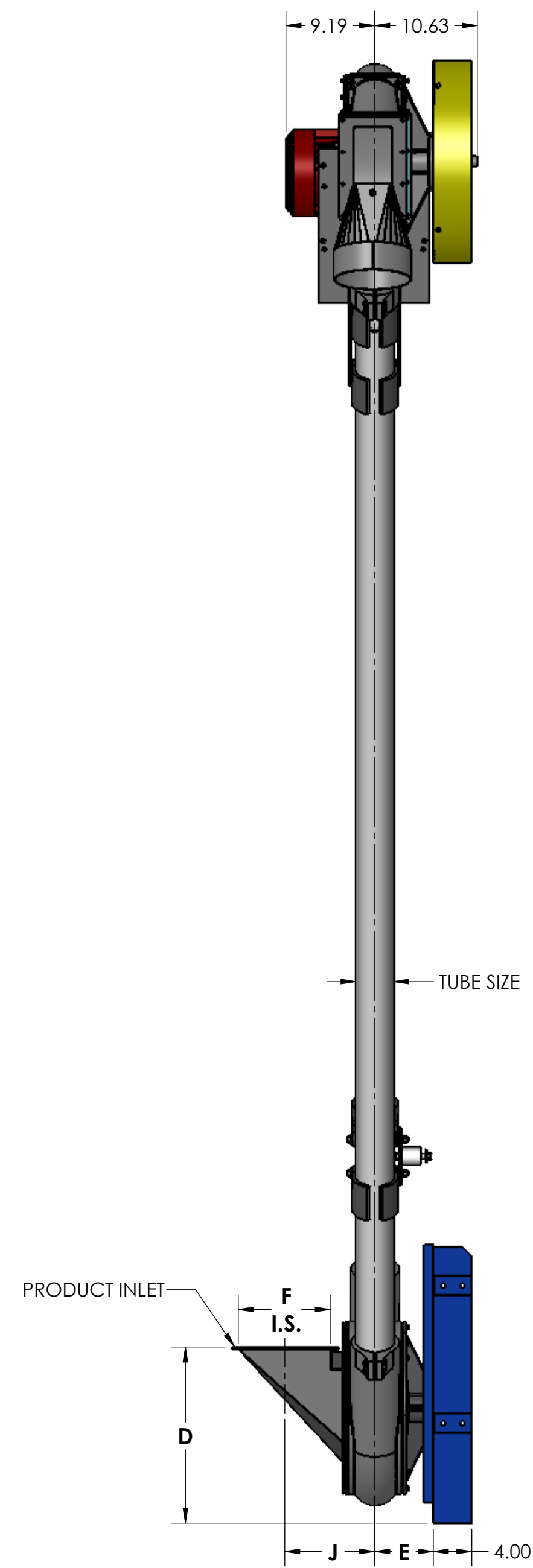

THIS IS A PRELIMINARY SKETCH ONLY. DIMENSIONS ARE ESTIMATED. NOT FOR FABRICATION

TUBE SIZE	A	B	C	D	E	F	G1 x G2	H	J	K	L	M	N	P	R	S	T
3"	11.50	9.50	20.00	14.38	5.08	7.88	24.00 x 20.00	18.88	8.31	9.50	10.25	7.75	3.12	30.00	4.69	4.38	2.59
4"	15.25	11.38	20.00	17.63	6.00	9.56	24.00 x 20.00	23.50	9.31	11.13	10.63	9.56	3.25	30.00	4.88	5.22	4.94

UNIT WEIGHT
LBS

GENERAL TOLERANCES	
UNLESS OTHERWISE SPECIFIED THE FOLLOWING SHALL APPLY	
MACHINING - .XX= .02 .XXX= .005 ANGLE= .50°	
SURFACE ROUGHNESS HEIGHT 63 MICRONS OR LESS	
FABRICATION - UNDER 6 6 TO 24 24 TO 60 OVER 60	
± .06 ± .12 ± .19 ± .25	

REV. NO.	DESCRIPTION	DATE	BY
REVISIONS			
CUSTOMER:			
CUSTOMER PO NUMBER:			
YOUNG JOB NUMBER:			
TITLE			
YOUNG INDUSTRIES TRANSAIR MECHANICAL CONVEYOR (TMC), MODEL 'SL' TOP DRIVE W/ SHAFT MOUNTED DRIVE, SIZE 3" & 4"			

THE YOUNG INDUSTRIES, INC.
 MUNCY, PENNSYLVANIA 17756
 TELEPHONE: 570-546-3165

DRAWN BY: BMF	DATE DRAWN: 7/12/16
CHECKED BY:	SCALE=1:12
DRAWING NUMBER: S-4-6297	SHEET 1 OF 1
	REV: